

Open doors

An abridged version of the Dies lecture delivered at Leiden University, 8 February 2021

Ineke Sluiter

Esteemed Rector Magnificus, former and current members of the Executive Board, dear online viewers,

The importance of doors

‘It’s something you shouldn’t underestimate!’ said my PhD candidate Daniël Bartelds, who was also department head at Stanislascollege, a school in Delft. ‘When pupils walk through the school doors, something changes at a stroke. They enter an environment where other rules apply and other behaviour is the norm. This transition helps them learn more effectively. They miss out on this moment of transition and this experience when they simply have to switch on their computer at home.’ Clearly, we were talking about the effects of lockdown and home schooling.

Daniël was remarking on a phenomenon that is also recognised scientifically. Doors and thresholds structure how we deal with the spaces in which we move around, and they mark meaningful instances of transition.ⁱ They influence our cognitions and emotions. This effect is greater when the space we are in is teeming with stories from the past, which is certainly true for a school and also for a university. There are good reasons why thresholds and doors also signify more in our language use than a piece of technology that lets you either enter or leave a space. ‘Jesse Klaver is a wonderful young man,’ he said the late lamented Hans de Boer, chair of VNO-NCW, a few years ago, ‘but, obviously, you have to lead someone like him over the threshold of wisdom.’ⁱⁱ Doors can either welcome or exclude. There is a set of norms associated with them that determine who may enter, and that also prescribe conduct. In short, they do much more than being open or closed, opening or closing, or being opened or closed, although linguistically there are interesting things to say about all these statements. Now that, in this time of the pandemic, we are allowed only a minuscule gathering here in the Pieterskerk, the importance of this annual ritual touches me more deeply.

There are times when our modern wonder at technology clouds our understanding of the significance of a door. A good instance of this is a remarkable exemplar from classical antiquity (see image 1): a door that opens automatically, complete with instructions for constructing it. This contraption was designed to be part of a miniature temple area that was in turn located somewhere on the site of a large temple complex. The construction worked on atmospheric pressure. When a fire was lit on the altar of the complex, a system of pulleys opened the doors automatically. However, we shouldn’t get too overcome by the ‘wow’ reaction to automatic doors in the ancient world. These doors were not intended for passing through to enter or

leave an area, which explains why automatic doors weren't introduced throughout the ancient world. They were important for two reasons: they elicited a sensation of wonder, amazement and pleasure in the observer, a feeling eminently suited to a temple environment, and they signified that the deity accepted the offering, welcoming it with benevolence.

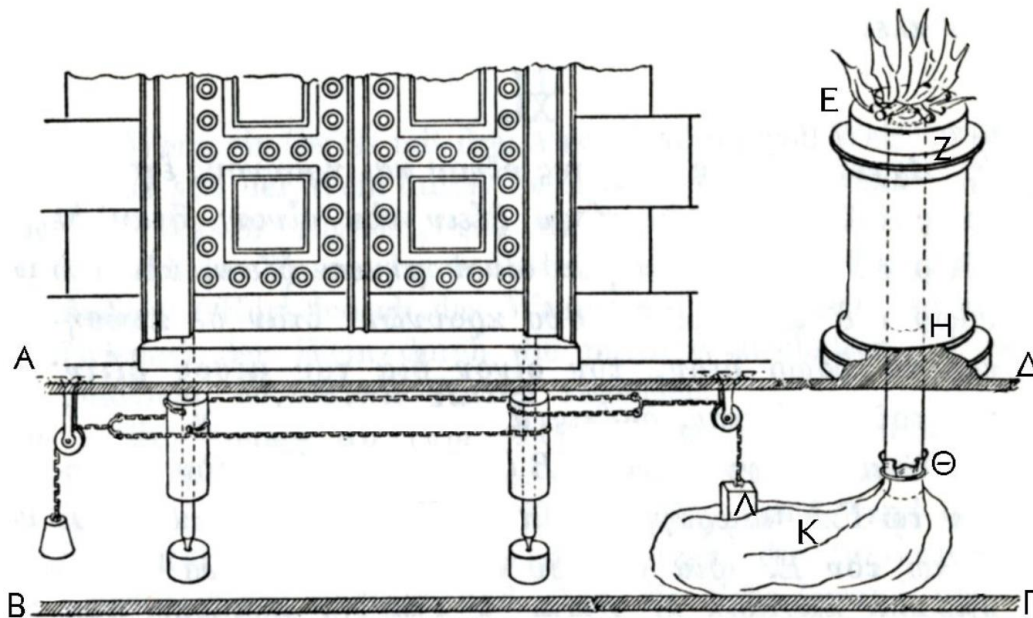

Figure 20: T9.b Alternate set up for temple doors to open automatically

Image 1, Tatiana Bur 2016.

We also need to go outside academia!

We in academia cannot be simply satisfied that these doors have opened for us, that we are part of the academic community, that we are insiders. It's also our duty to go outside the institution, literally or figuratively, to share our knowledge and insights and put them to good use, to fuel and inform the societal debate. The doors have to be open, not only to the inside but also to the outside world!ⁱⁱⁱ

That often works just fine. Academics from Leiden regularly play a role in the media, for example. But we also know that, by doing so, they expose themselves to the less pleasant aspects of social media. Twitter would be well served if it too had a door, not to keep people inside or out, but above all to demarcate the space and to mark the transitions between the two. There is no clear signal to the user that by sending a tweet you are leaving the seclusion of your private sphere, and entering into the public arena – where you normally behave differently.

Online vitriol

Right now, social media is suffering from an excess of online vitriol, as a recently published book edited by our Leiden colleague Sara Polak and Rotterdam colleague Daniel Trottier, describes.^{iv} You don't need to spend long on YouTube, Facebook or Twitter to find examples aplenty. Twitter itself, a veritable sewer of bile, is aware that something is wrong with the online climate. It promoted a line of research by Rebekah Tromble, started when she was still in Leiden, and political scientist Michael Meffert, who, fortunately, is still here,^v that asked how you can determine whether a conversation is still healthy. Does it encourage a silo culture? Are diverse perspectives still being offered? What's the position on incivility? Are there signs of intolerance? The distinction between incivility and intolerance is particularly interesting. Incivility infringes a norm of politeness or courtesy, but can nonetheless serve a purpose in the political debate, for example when minorities use strong verbal means to draw attention to their viewpoint. There are good reasons why freedom of expression is defined in such a way in the legislation to expressly leave room for opinions that may be shocking or offensive, or that can disturb our peace of mind. But intolerance is a different matter. It includes such things as hate speech, racism, xenophobia and other discriminatory practices that inherently constitute a threat to an open society, and are consequently undesirable, and yes, even illegal. Tromble's team is also not in favour of the term 'troll', however graphic an image the word conjures up. They believe the term causes us to lose sight of the very relevant differences within this group and consequently to miss the opportunity to adjust our reactions to these differences. Are these Twitter users angry? Crazy? Dangerous? It makes quite a difference: there may still be room for dialogue, especially with Twitter users who have let themselves get carried away, spurred on by a surge of anger.

Vitriol and academia

The climate on social media also affects academics whose expertise and profession lead them to take part in social debates. It is a subject that itself warrants further research. A number of our academics are subjected to aggression and threats, which can even include posting photos of their children. These are generally the people who write and talk about socially sensitive issues, and who are more visible and prominent. These are, of course, scholars of which universities are rightly proud – and so should they be, not least because these academics understand more than anyone else that the door to academia also opens outwards.

I do not intend even for a second to trivialise what is happening to a number of my male colleagues, who deserve the full support of their university and their fellow academics, but I have to say that there are more than strong indications that the hypercriticism evident on social media is primarily directed at women, or in any event it attacks women in a particular way. And the same applies for people of colour. I will first give some examples of women in politics and journalism, and will then talk about the academic world.

It is easy to imagine what happens when racism and misogyny come together. Amnesty International discovered that in the British election campaign in 2017 there was one woman who was the object of half of all online hate aimed at female members of parliament: Diane Abbott, a Labour politician of colour.^{vi}

In fact, 'simply being a woman' is enough. Female newsreaders are thought to be less trustworthy than their male counterparts.^{vii} Women journalists are often the recipients of critical, offensive, marginalising, stereotypical and threatening reactions.^{viii} On YouTube, the science communication channels that have female presenters receive more comments, and those comments include a significantly higher proportion of remarks about physical appearance, negative criticism and hostile, sexist and sexual remarks.^{ix}

Representation is another issue: on Wikipedia, a study was made both of the editors and the frequency with which items were written *about* women. Sam Baker's study in 2019 shows that 80 per cent of Wikipedia editors are men, and only 17 per cent of the biographies on Wikipedia are about women. When females edit Wikipedia articles, they find that their edits are often reversed with no consultation, they receive unwanted sexual advances and they are stalked and doxed; in other words, their personal data are traced and made public. They even receive death threats. On the subject of those Wikipedia biographies: Donna Strickland, winner of the Nobel Prize for Physics in 2018, didn't have a Wikipedia page. A page was submitted, but it was rejected because not enough had been written about her in the media. It is only since the Nobel Prize that Donna Strickland can be found on Wikipedia – apparently, the bar is set very high.

Reactions to female academics on social media

What is the situation with female academics and social media? Here, too, some information is available. Such as the appeal by three female scientists in *The Lancet* who spoke out about cyberbullying^x, and the personal experiences of two female researchers who found themselves embroiled in a Twitter storm.^{xi} For the time being, this is anecdotal and hasn't yet been systematically studied. We have known for some time that women from the STEM disciplines who are involved in science communication suffer from being stereotyped as 'bitchy, bossy, undeserving', and those comments come from both men and women.^{xii} Or that women who look more feminine are less likely to be regarded as 'real scientists'.^{xiii} The effect of implicit prejudices and gender stereotypes has been well described by Naomi Ellemers.^{xiv}

I was prompted to discuss this issue today by the experiences of valued and highly esteemed colleagues, men such as Leo Lucassen and Gert Oostindie, and women such as Beatrice de Graaf and Marion Koopmans. Marion Koopmans reported how after every media appearance her Twitter timeline is flooded with criticisms and threats.^{xv} Such threats are, of course, totally unacceptable! Beatrice de Graaf, too, quite rightly protested about the extremely offensive nature of some of the reactions to her professional appearances in the media.

The damage

The damage inflicted by all of this is considerable. For the men and women who are subjected to it, it is an attack on their sense of social safety. The effect on everyone who is the target of online vitriol can be chilling; it leads to a type of self-censorship where people prefer to avoid public activities rather than expose themselves to online aggression. This effect seems to apply more strongly to women, possibly because of the particular form that the threats and insults aimed at them take.^{xvi} They are stripped online of all the characteristics and qualifications that they have worked so hard to achieve, and that they have put to good use to bring their expert knowledge into the public domain. They are reduced to nothing more than gender stereotypes and are confronted with obscene notions and prejudices. But a lack of expert knowledge in public discourse would impoverish us all. And when women disproportionately shun the media, assuming they were invited in equal measure in the first place, we as a society miss out on their talent, insights, information and perspectives.

What we can do: Praesidium libertatis

It takes courage for an academic to be active in the public domain. And courage is something that our colleagues – both men and women – show every day. ‘What would become of the world if everyone with something reasonable to say let themselves be silenced?’ asked Marion Koopmans in the *AD*.^{xvii} Universities, and that includes ours, encourage us to let our opinions be heard – in the form of impact, outreach, visibility. Universities are proud when their experts find a platform. Not allowing yourself be deterred by the backlash of publicity is certainly also a quality, and those scientists who are prepared to represent the voice of expertise and reason in the full glare of the public eye are truly fulfilling the mission of *Praesidium libertatis*. But institutions that flaunt their well-known scientists also have to take action to protect them if they find themselves in the eye of the storm.^{xviii} And that applies not only to the institutions themselves: we too, all of us, as colleagues, have to show ourselves to be ‘active bystanders’, alert observers who don’t just avert our eyes when these things happen to our colleagues.^{xix} This is also inherent in *Praesidium libertatis*, the role of our university as a bastion of freedom.

So, what can we do? To start with, we can be more professional in the support we offer our people, and not leave them to their own devices. There are lessons to be learned from an organisation like ‘TrollBusters’, set up by Michelle Ferrier, that offers guidelines on how to support journalists who experience online harassment (see image 2).^{xx} Do our communication and legal departments have this kind of practical information at their fingertips? Do managers immediately call their staff if they see or hear that they are under fire? And what do we ourselves do as colleagues? Do we offer help and support? Are we able to moderate our reaction so that we don’t say: ‘You were pretty outspoken there, weren’t you?’ or ‘Well, you

really got it in the neck this time, didn't you?' These examples are taken straight from real life and reek of victim blaming and scarcely concealed malicious gloating.

Online abuse is not normal. However, it is no simple matter to know what interventions are likely to be successful. If in a normal conversation someone violates a social norm, for example, by making a discriminating remark, and we allow a micro-silence to fall in the to and fro of conversation, this in itself is enough to make the observers understand that the comment went beyond the shared norms of the group. But if people just carry on talking, that too is an indication – in this case, that the group sees nothing wrong with the remark.^{xxi} Obviously, Twitter is not the place for such subtle corrections. It would be good if our university, possibly together with VSNU, were to start a 'social safety online' taskforce to generate tips for anyone who is affected by online vitriol, for the academic's institutional environment and for the network of colleagues.

ARE YOU BEING HARASSED ONLINE? TrollBusters provides online peer control for writers, journalists and publishers. Report to www.troll-busters.com. If you are not a journalist, check our Resources for more tips and information.

Step 1: What is happening right now?

- Someone is attacking my website.** A denial of service (DoS) attack is a malicious attack to make a server or a network resource unavailable to users. A DDoS is an attack by multiple computers.
 - Tip #5: Get technical support from companies such as CloudFlare, Sucuri, or Inopress.
 - Tip #14: If the website being targeted is an independent media site, a human rights site, or a public interest site, you may be eligible for free DoS protection. Tip #2: If you are a free-to-use resident in the British Isles, you may be eligible for free legal aid through the Harassment Legal Aid Scheme.
- Someone is doxing me.** Doxing is the practice of breasting private or identifiable information.
 - Tip #1: Lock down your physical location. This can include developing a home security plan or moving, although not recommended.
 - Tip #1: If someone is posting stuff, happenings, create a paper trail to case you wish to take further action with law enforcement or the platform.
 - Tip #1: Notify your friends about what is happening.
 - REPORT: 1. Report to the police. 2. Report on Twitter. 3. Talk to your lawyer about what is happening. Decide how you should approach the harassment and whether others should monitor your social media accounts. 4. Document.
- Someone is posting sexually explicit photographs of me without my consent.**
 - Report to Twitter or Facebook. If you are a victim of sexual harassment, you can report it to the police.
 - Consult an attorney. Many states have laws that have violated to help victims of sex-related pornography. If you are a victim of sexual harassment, you can report it to the police.
 - Make sure to document everything that is happening to create a paper trail for your own records in case you wish to take further action with law enforcement or the platform.
 - OUR REPORT: Remove sexual content. Remove posts that are sexual in nature. Remove posts that are sexual in nature. Remove posts that are sexual in nature. Do not block.
- Someone has posted an implied threat.** Example: "People like you should be shot."
 - Be aware that legally this may not be considered a threat.
 - Choose whether to engage with or block or mute.
 - Go to REPORT.
 - Tip #1: Monitor, screenshot anything all which is posted on social media. Do not post anything on social media. Do not post anything on social media. Do not post anything on social media.
- Someone has posted an explicit threat.** Example: "I am going to kill you."
 - Lock down your physical location. Tip #1: Report to the police. Tip #1: Talk to your lawyer, if appropriate. Tip #1: Go to STOP LOOKING UNDER SOMEONE HAS POSTED AN INSULT. Resources: www.trollbusters.com, www.trollbusters.com.
- Someone has posted an insult.** Example: "You need to learn how to write."
 - STOP LOOKING: Ignore the comment and continue using Twitter as usual. Go offline for a while and you regroup. Make the post. They won't know you have been muted. If you follow the user, you will still see their replies and mentions in your email notifications, but you won't see them if you do not follow the muted account. Build the account. This will stop the person from following you and from seeing or reacting your tweets from their account. (They may however, have other accounts and will still be able to see your public tweets when not logged into the blocked account.) Have a few minutes to think about if you put in care how you interact and what to document or be made aware of.
- Someone has posted a critique.** Example: "A better reporter would have considered the economic impact of the proposal."
 - Choose whether to engage or ignore the user. (You can block to see other tweets they've made to get a sense of how the conversation is far to go.) OR Go to STOP LOOKING.
- Someone has posted a libelous comment.** Libel is a false statement intended to harm your reputation, publicly contradict with facts and testimonials.
 - Have a handy jump to comment on your behalf, or to report any offending tweets. Visit www.trollbusters.com for more.
 - Go to STOP LOOKING. Go to REPORT. Resources: www.trollbusters.com, www.trollbusters.com.
- Someone is impersonating my account.**
 - Report the impersonator to Twitter. (You will need to share your ID with them to prove that the impersonator happened.) Apply for verification. If you do get a verified account, it can help you to authenticate your identity. Go to REPORT.

Step 2: What happened next?

- It goes away:** End.
- It escalates to a threat:** Go to the top of the chart.
- It escalates to more harassment:**
 - If they are human:
 - Block the account.
 - Check out back links created by others.
 - Report to followers.
 - If they are a bot:
 - Are you one of multiple people targeted?
 - No: Go through the appropriate threat steps. REPORT.
 - Yes: Reach out to targeted accounts. Consider starting a block list with other people who are targeted. Document for your own records.
 - Are you one of multiple people targeted?
 - No: Then go to the top of the chart. REPORT.
 - Yes: Then go to the top of the chart. REPORT.

Things to document:

- Number of tweets.
- Details (date, time, picture of tweet).
- Number of people involved.
- Severity of the attack (e.g. blocking).

Twitter Settings:

- Change Twitter settings to ensure you only see what you want.
- You can filter tweets by only people you follow, which means that you'll only see notifications from those accounts.
- Twitter also has a quality filter, which filters out low-quality content from people you don't follow and have not recently interacted with.
- In addition to being able to mute or block users, you can also make specific needs.
- If you choose to filter or block your tweets, you may want to have someone check the offensive accounts to see if tweets against you have escalated.

Who to contact as a student:

- If you are a student, contact the Student Press Law Center, and report any incidents to your faculty advisor, if appropriate.

TROLLBUSTERS
Copyright 2017. All Rights Reserved.
Report to www.trollbusters.com.

Image 2: <http://www.troll-busters.com/>.

And Homer

I am nearing the end of this Dies lecture. But, it will not have escaped your notice that I have not yet mentioned Homer. Let me put that right, because in the *Iliad* there is a highly

interesting passage about ... automatic doors. At a certain point, Hera and Athena are in their chariot *en route* to Olympus. Hera has the reins. As they approach, the doors of Olympus open automatically, 30 centuries before the invention of automatic garage doors, as Daniel Mendelsohn puts it. The Greek says: *Automatai*. Just like the miniature temple complex, it isn't the fact that the doors open automatically that is significant. The doors open automatically because they are part of the world of the gods, where all is golden and everything proceeds effortlessly. What is really interesting is the verb that is generally translated as 'to open', because this word actually describes a groaning, creaking or lowing sound (*mukon*).^{xxii} This sound is not a sign of poor maintenance. The reason that the doors creak is that *all* doors in ancient times creaked. No, it is once again what the opening signifies that is important. It is difficult for us to imagine where exactly these doors were located, but we do know for sure that the doors opened for the goddesses because of the sound that was reported. And that sound is evidence of their entry into Olympus. This kind of warning sign is just what Twitter lacks. And it is what our students miss in the structure of their lives by being unable to pass through the open doors of the lecture hall.

I happen to know that in the distant past our new Rector played the goddess Hera in a school performance of the *Iliad*. Today, with the opening of the doors of Pieterskerk, Olympic doors are also opening for an H and an A. Their task will be to see that these doors often remain open in the coming years so that anyone who enters is able to contribute to an inclusive and diverse university, and anyone who passes through those doors to the outside, can put *praesidium libertatis* into practice with support from the top. I wish Professors Hester Bijl and Annetje Ottow every success, and hope that this whole lecture will soon have the effect of an open door. Finally, I would like to thank Leiden's Twitter Rector Carel Stolker for the many positive messages with which he has brightened social media in recent years. He is one person who is blameless.

I have spoken.

Word of thanks:

I was prompted to draw attention to the online harassment of women academics who venture into the media having listened to a courageous lecture given by Professor Beatrice de Graaf to a group from the Royal Netherlands Academy of Arts and Scientists (KNAW). I would like to thank her for this! Thanks also to the friends and colleagues of Athena's Angels: Naomi Ellemers, Eveline Crone and Judi Mesman for all their input, references and for the important discussions we have had over recent years. I am also grateful to the men from the Leiden lexico team (Greek-Dutch dictionary): Lucien van Beek, Stephen van Beek, Daniel Bartelds and Janric van Rookhuijzen for an inspiring conversation about doors.

Bibliography:

For more material, see the website of Athena's Angels: <https://www.athenasangels.nl/nl/>

Amarasekara I., Grant WJ., 2019. 'Exploring the YouTube science communication gender gap: a sentiment analysis', *Public Understanding of Science* 28.1, 68-84.

Amnesty International, 2018. *Toxic Twitter: A Toxic Place for Women* (chapter 3: *Women's Experiences of Violence and Abuse on Twitter*).
<https://www.amnesty.org/en/latest/research/2018/03/online-violence-against-women-chapter-3/>

Baker S., 2019. 'Making space for female scientists' voices online, in the media, and in person', *Deutsche Welle (DW)* 19-06-2019 (<https://www.dw.com/en/making-space-for-female-scientists-voices-online-in-the-media-and-in-person/a-49258608>, last visited on 30 January 2021).

Banchefsky S., Westfall J., Park B., Judd ChM., 2016. 'But you don't look like a scientist!: women scientists with feminine appearance are deemed less likely to be scientists', *Sex Roles* 75 (3-4) DOI: [10.1007/s11199-016-0586-1](https://doi.org/10.1007/s11199-016-0586-1)

Becker JC., Zawadzki MJ., Shields SA., 2014. 'Confronting and reducing sexism. A call for research on intervention', *Journal of Social Issues* 70, 637-652 (<https://psycnet.apa.org/record/2014-55023-001>).

Brann M., Leezer Himes K., 2010. 'Perceived credibility of male versus female television newscasters', *Communication Research Reports* 27.3, 243-252
DOI: [10.1080/08824091003737869](https://doi.org/10.1080/08824091003737869).

Bur T., 2016. *Mechanical Miracles. Automata in Ancient Greek Religion*. Diss. Univ. of Sydney.

Dongen, Annemieke van, 2020. 'Topviroloog Koopmans kreeg veel kritiek dit jaar', *Algemeen Dagblad* 20-12-2020.

Ellemers, Naomi, 2018. 'Gender Stereotypes', *Annual Review of Psychology* 69, [10.1146/annurev-psych-122216-011719](https://doi.org/10.1146/annurev-psych-122216-011719).

Engels, Joep, 2020. 'Marion Koopmans: die bedreigingen zijn niet oké', *Trouw* 19-12-2020.

Gadde V, Gasca D., 2018. 'Measuring healthy conversation', 30-07-2018
https://blog.twitter.com/en_us/topics/company/2018/measuring_healthy_conversation.html

Gennep A. van, 1909. *Les rites de passage. Étude systématique des rites de la porte et du seuil*. Paris [translated by Vizedom MB., Caffee GI. 1960 repr. 2004 *The rites of passage*]. London.

Graslie, Emily, 2013. 'Where my Ladies at?', *The Brainscoop*, The Field Museum Chicago, 27-11-2013 <https://www.youtube.com/watch?reload=9&v=yRnt7ZLY0Kc>.

Kemekenidou P., 2020. 'r/ChokeABitch. Feminist tactics against hate speech in capitalist social media platforms', in: Polak & Trottier, 233-249.

KNAW, 2020. <https://knav.nl/nl/actueel/nieuws/knav-gaat-adviseren-over-preventie-ongewenst-gedrag-in-de-wetenschap>

KNAW, 2021. *Staan op Kennis. Strategische Agenda 2021-2025*. Amsterdam <https://www.knav.nl/nl/actueel/nieuws/staan-op-kennis-de-ambities-van-de-knav-voor-de-komende-jaren>.

Koudenberg N., Kannegieter M., Postmes T., Kashima Y., 2020. 'The subtle spreading of sexist norms', *Group Processes and Intergroup Relations* Oct. 2020 <https://doi.org/10.1177/1368430220961838>

Latané B., Darley JM, 1970. *The Unresponsive Bystander: Why doesn't he help?* New York: Appleton-Century Crofts.

McDonald L., Barriault Ch., Merritt Th., 2020. 'Effects of gender harassment on science popularization behaviors', *Public Understanding of Science* 29.7, 718-728.

McKinnon M., O'Connell Ch., 2020. 'Perceptions of stereotypes applied to women who publicly communicate their STEM work', *Nature: Humanities and Social Sciences Communications* 7, art.# 160 <https://www.nature.com/articles/s41599-020-00654-0>.

Norris S., 2018. 'Tackling the trolls: how women are fighting back against online bullies', *Open Democracy* 15 August <https://www.opendemocracy.net/en/5050/tackling-trolls-how-women-fighting-back-online-bullies/>.

Opstall, Emilie M. van (ed.), 2018. *Sacres Thresholds. The Door to the Sanctuary in Late Antiquity*. Leiden: Brill.

Polak S., Trottier D. (eds.), 2020. *Violence and Trolling on Social Media: History, Affect, and Effects of Online Vitriol*. Amsterdam: Amsterdam University Press.

Powell A., 2014. *Bystander Approaches: Responding to and preventing men's sexual violence against women*. Melbourne. <https://aifs.gov.au/publications/archived/3785> [last visited 29 Jan. 2021].

Radvansky, GA, 2012, 'Across the event horizon', *Current Directions in Psychological Science* 21, 269-272.

Samer C., Lacombe K., Calmy A., 2020. 'Cyber harassment of female scientists will not be the new norm', correspondence *The Lancet* 23 December.

Tsou A., Thelwall M., Mongeon Ph., Sugimoto C., 2014. 'A community of curious souls: an analysis of commenting behavior on TED Talks videos', *PLoS one*.9.e93609.10.1371/journal.pone.0093609.

TrollBusters—Online pest control for journalists: <http://www.troll-busters.com/>.

Veletsianos G., Kimmons R., Larsen R., Dousay TA., Lowenthal PR, 2018. 'Public comment sentiment on educational videos: understanding the effect of presenter gender, video format, threading, and moderation on YouTube TED talk comments', *PloS one*
<https://doi.org/10.1371/journal.pone.0197331>

Yelin H., Clancy L., 2020. 'Doing impact work while female: hate tweets, 'hot potatoes' and having 'enough of experts', *European Journal of Women's Studies*, 3 March.

Waterval D., 2021. 'In memoriam Hans de Boer', *Trouw* 18-01-2021
<https://www.trouw.nl/economie/hans-de-boer-1955-2021-werkgeversvoorman-die-in-een-oranje-hesje-op-het-malieveld-stond~b4ff12d0/?referrer=https%3A%2F%2Fwww.google.com%2F> (laatst bezocht 30 jan. 2021).

ⁱ Van Opstall 2018; van Genneep 1909 (1960); for the relationship with memory: Radvansky 2012.

ⁱⁱ Waterval 2021.

ⁱⁱⁱ Also one of the objectives of the new strategic agenda of KNAW 2021.

^{iv} Polak & Trottier 2020.

^v Gadde & Gasca 2018.

^{vi} Amnesty International 2018; Norris 2018.

^{vii} Brann et al. 2010.

^{viii} Chen et al. 2020. Whether this occurs more or less often than with male journalists is not researched in this study.

^{ix} Amarasekara & Grant 2019; see also the wonderful and personal story 'where my ladies at?' by presenter Emily Graslie on her YouTube Channel 'The Brainscoop', The Field Museum Chicago (2013); for reactions to female TEDtalk speakers, see Tsou et al. 2014; Veletsianos et al. 2018.

^x Samer et al 2020.

^{xi} Yelin & Clancy.

^{xii} McKinnan & O'Connell 2020: 'negative effects of gender-based stereotypes extend to public communication activities of women in STEM'.

^{xiii} Banchefsky et al. 2016.

^{xiv} Ellemers 2018. A KNAW commission headed by Naomi Ellemers will conduct research on preventing undesirable behaviour in science, in the context of the National Action Plan on Diversity and Inclusion (KNAW 2020).

^{xv} Van Dongen (*Algemeen Dagblad*) 2020; Engels (*Trouw*) 2020; she does not comment on the question of whether it makes a difference that she is a woman.

^{xvi} McDonald et al. 2020; Howell 2013.

^{xvii} Van Dongen (*Algemeen Dagblad*) 2020.

^{xviii} Yelin & Clancy 2020; Samer et al. 2020.

^{xix} Latané & Darley 1970; Becker et al. 2014

^{xx} As well as on the website of TrollBusters, there are also suggestions in Kemekenidou 2020, 241ff.

^{xxi} Koudenberg et al. 2020.

^{xxii} *Ilias* 5.748vv.